

The Containerized Future of Energy

Technical Report of the SGP (Smart Grid Power) Solution Generation, Storage, and Power

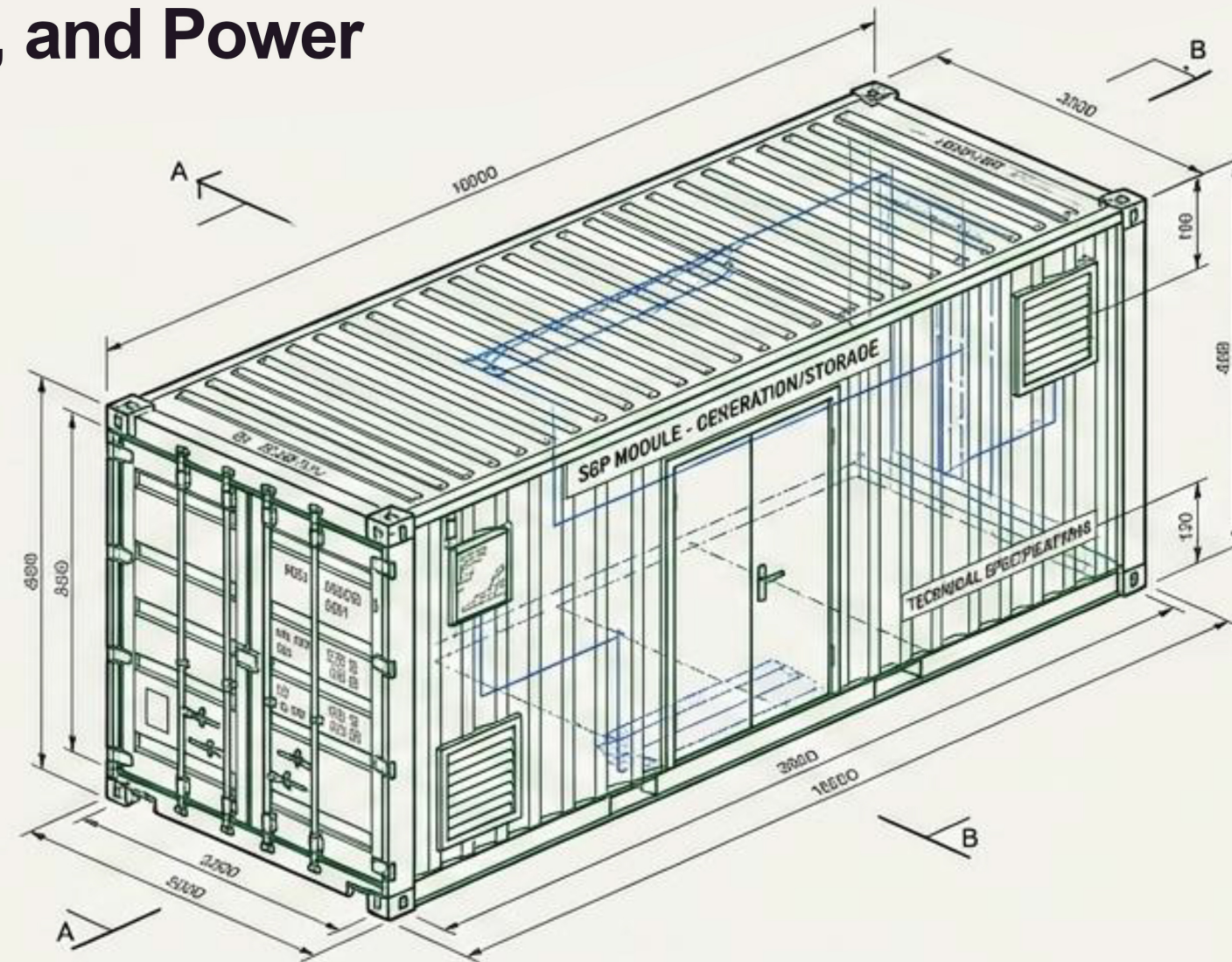

A structural analysis for CNPE, CMSE, MME, EPE, ONS, ANEEL, and CCEE.

0 SGP Blueprint: An Autonomous Hybrid Power Plant

The SGP is a multi-source, three-phase, independent, and sustainable power plant operating in an off-grid microgrid regime.

01

Physical Format:
Standard 40-foot
container.

02

Total Weight:
16,000 kg.

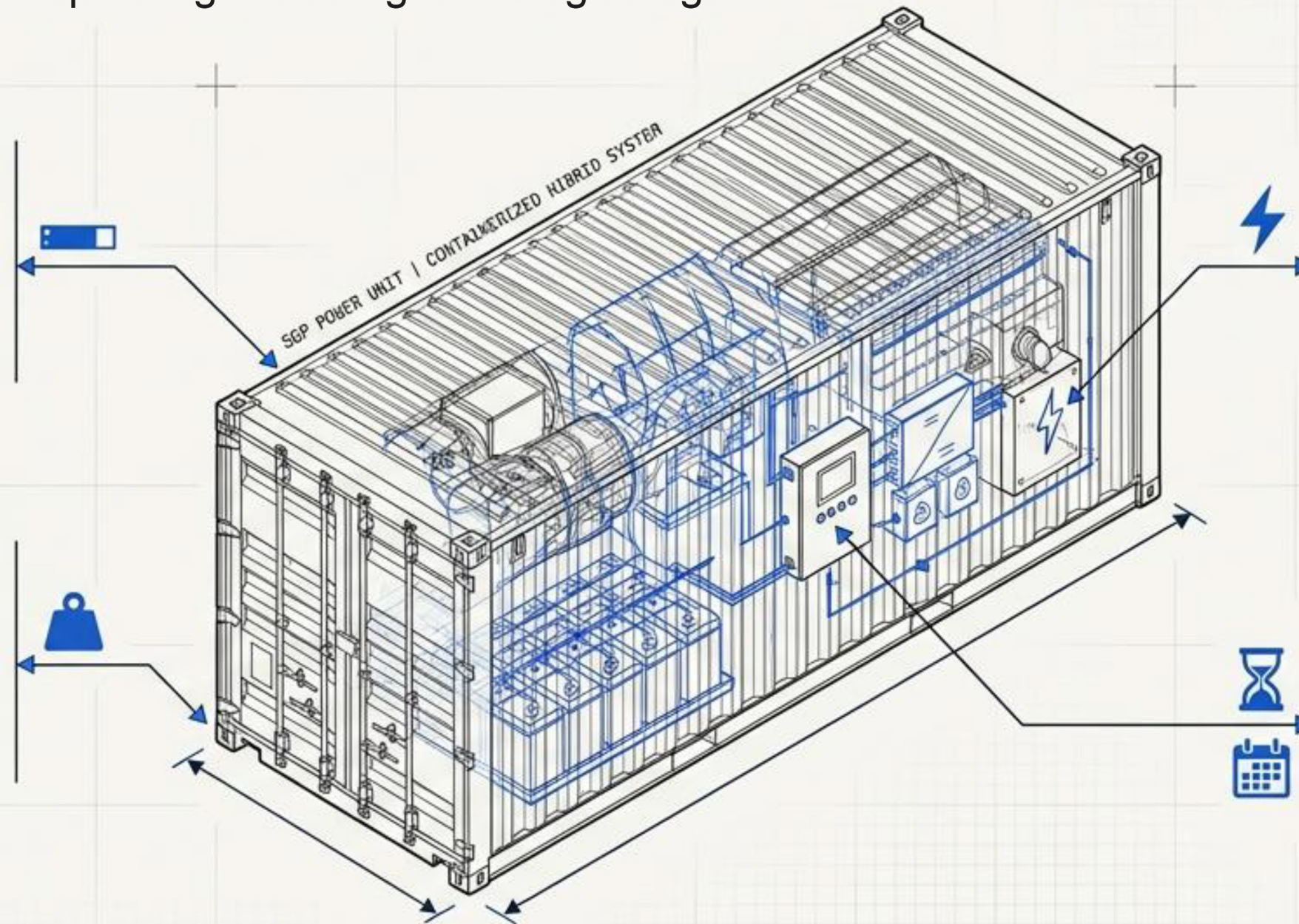

03

Output Power:
1,880 kW/h (1.88 MW/h)
continuous (24/7).

04

Lifespan Guarantee:
100,000 hours of
guaranteed operation /
Maximum capacity of
150,000 hours (~17
years).

Architectural X-Ray

Scale 1

Reservatório Nacional/54 mnsaaxo-ka s'nera 1195-

SGP TECHNICAL SPECIFICATIONS

NotebookLM

Hydrokinetic Motor: Generation in a Sealed System

Working Principle:
Sealed system
converting analog
energy into structured
digital energy, with
zero carbon emission

1. ESS All-in-one:
Origin of storage

2. Propulsion:
VFD and Synchronous
Motors.

3. Conversion:
Synchronous
alternators and
AVR

4. Power Elevation:
Low or medium
voltage

5. Distribution:
Routing system.

6. Digital Processing:
AI + IoT convert energy
with perfect curves

7. Digital Transformer:
Delivery on demand at
any voltage

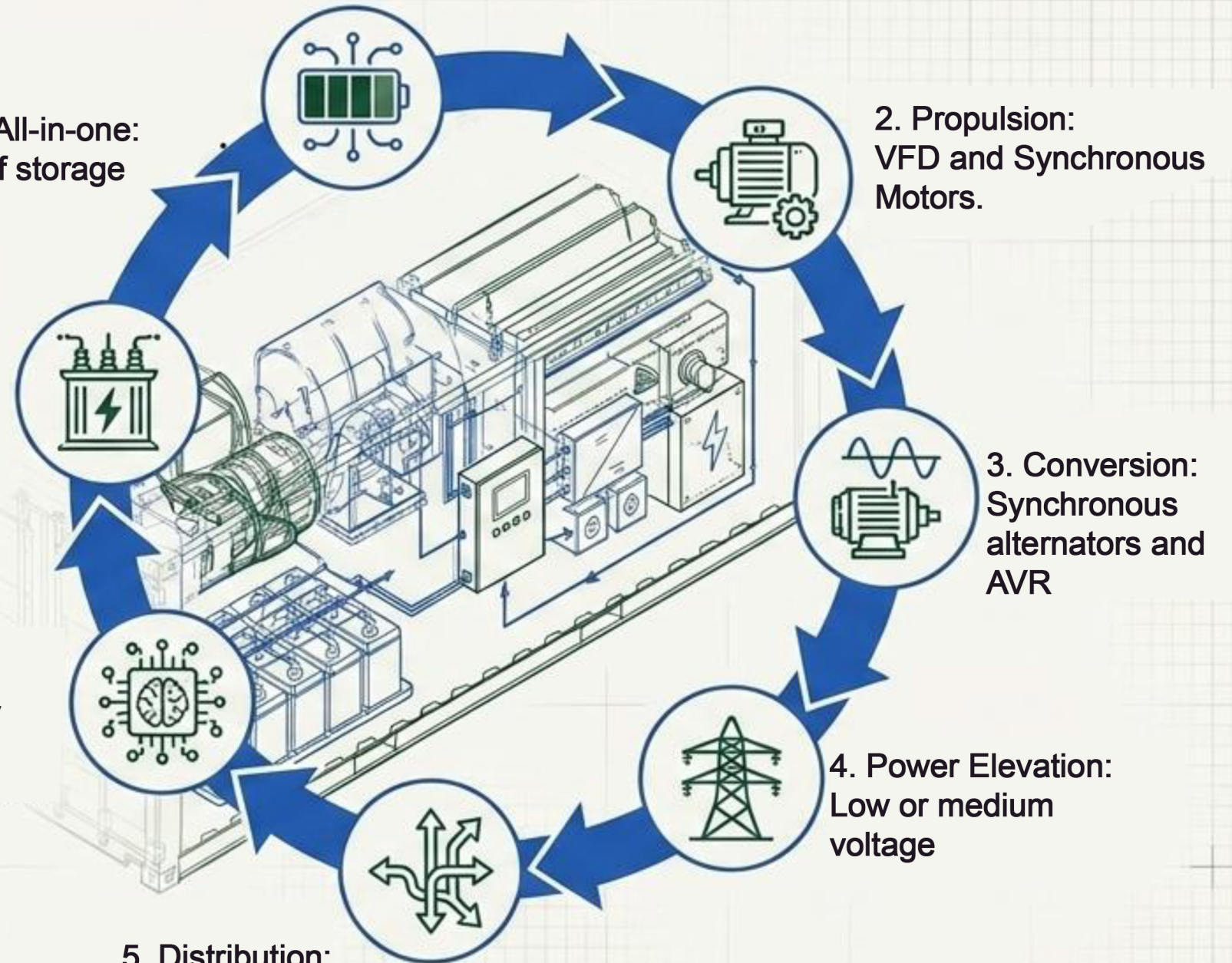





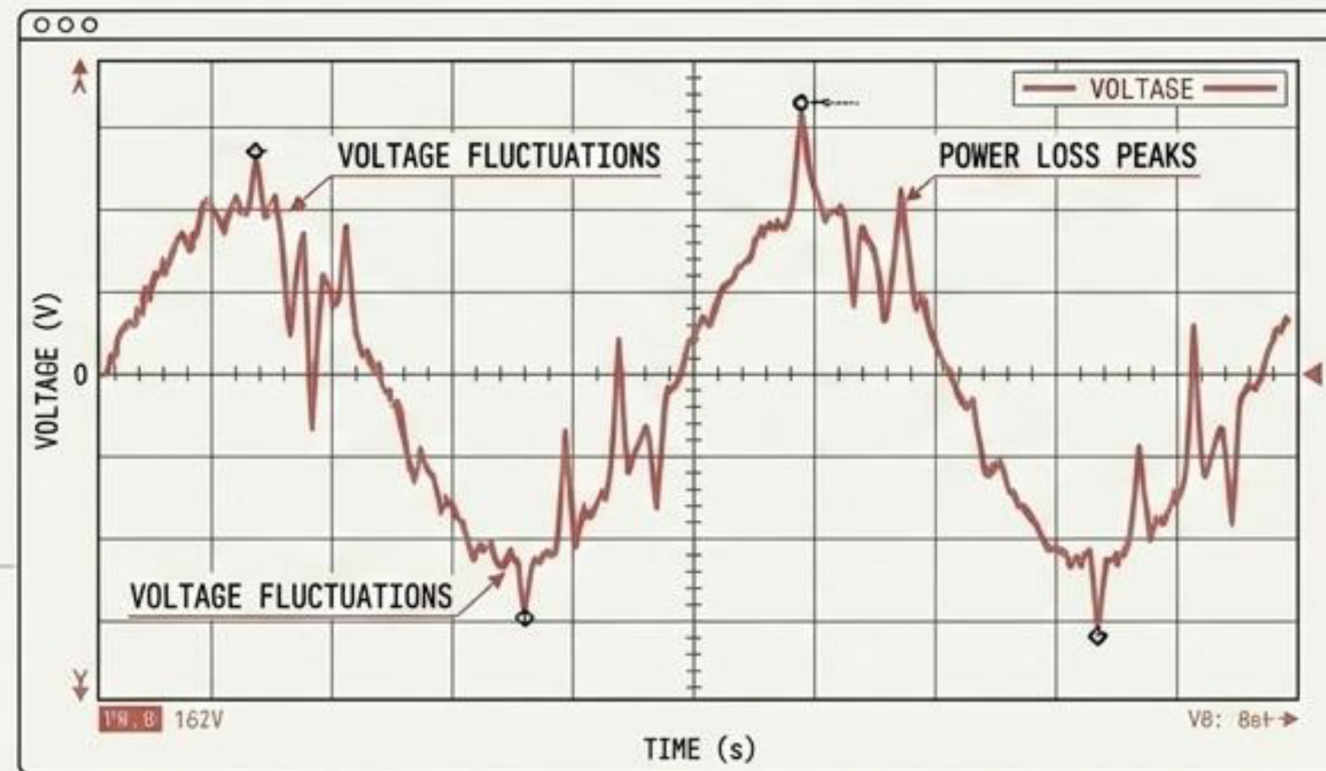

Digital Paradigm: Impeccable Efficiency

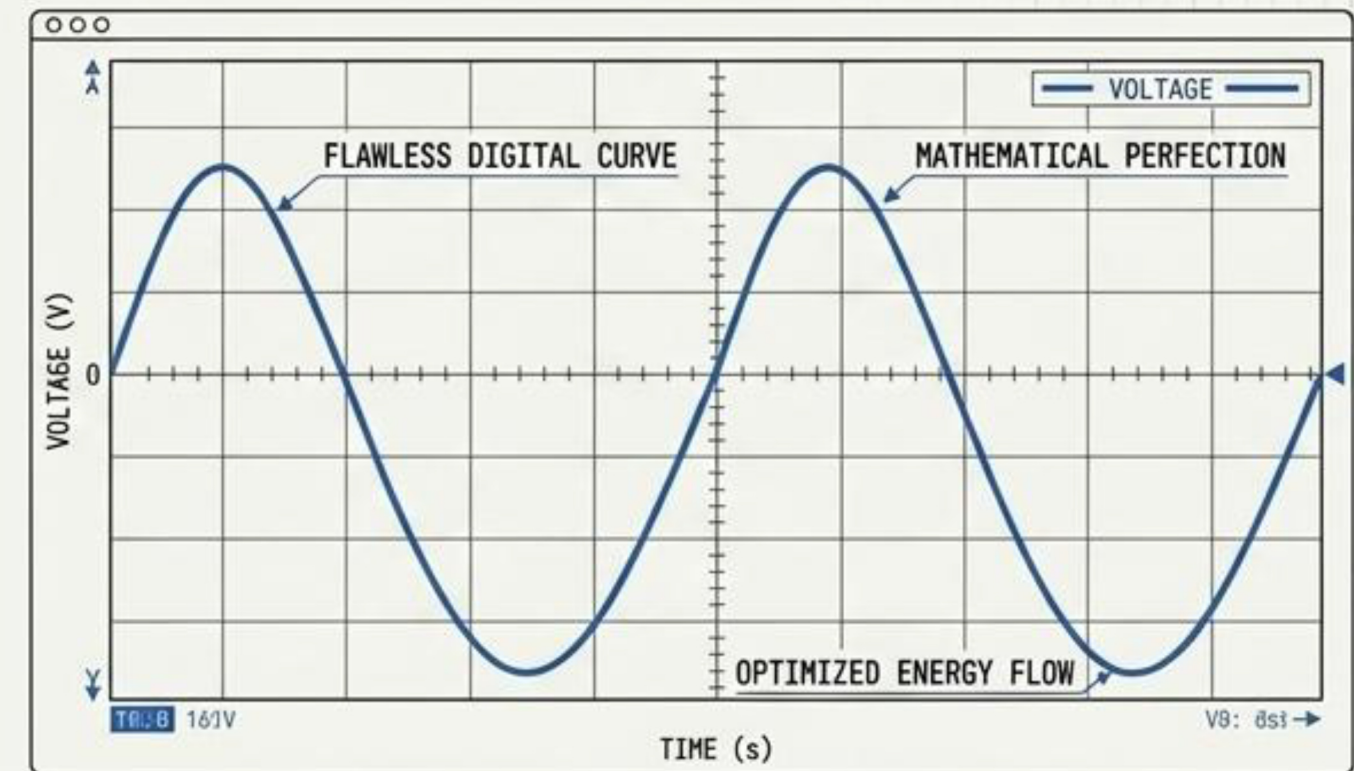
Analog Metric (Common Grid)



SGP Metric (Digital Energy)



Efficiency:	Standard.			3 to 5 times more efficient and economical. Harmonic
Harmonic Curve:	Subject to distortions and noise.			Mathematically perfect (AI + IoT base).
Operation Emissions:	Dependent on the central source.			Zero fuel, Zero emissions (100% green).

Delivery Dashboard: Universal Power and Voltage

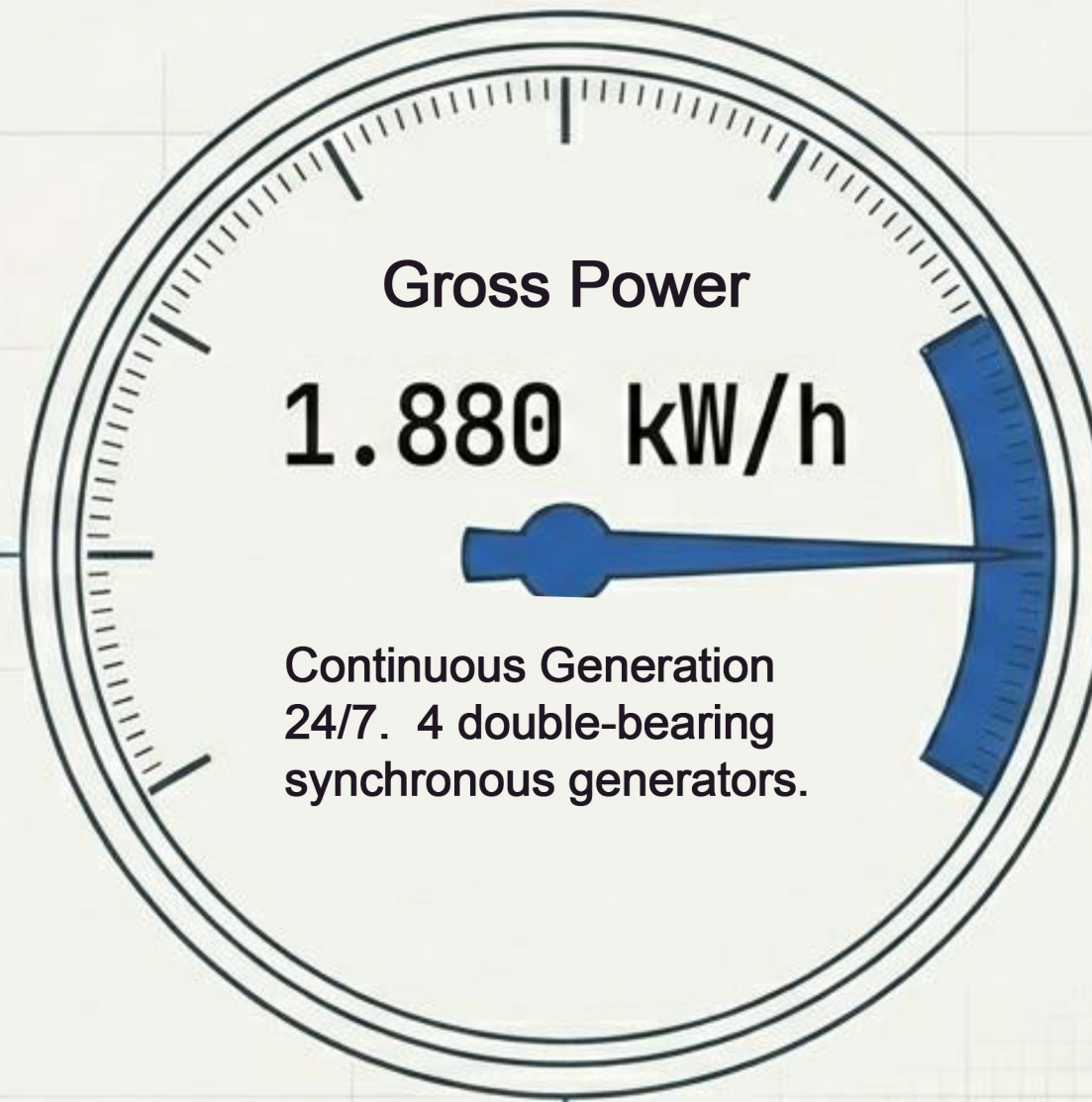

Voltage Flexibility

600V 480V 440V
 415V 380V 220V

Universal output configurable to
600V, 480V, 440V, 415V, 380V or

Instantaneous Current

BAIXA ALTA

Flexible from 100 to 1200 amperes.

Connectivity and Phase

TRANSFORMADOR
DIGITAL
PLUG-AND-PLAY

Three-phase (3/4 wires) via
Plug-and-play Digital Transformer.
50 Hz or 60 Hz.

Vertical text on the left side of the dashboard.

Architectural X-Ray

0 Scale 1

*Rzonalcloonte Múnarie/bê Massa para Beração e Conversão

SGP TECHNICAL SPECIFICATIONS

© NotebookLM

Resilience Dashboard: Storage and Control

Storage Capacity



Smart Batteries providing guaranteed tactical backup of up to 60 hours.

Communication Redundancy

Redundant satellite links and internal communication via Bluetooth.

Secure blockchain protocol (Tamper-proof).

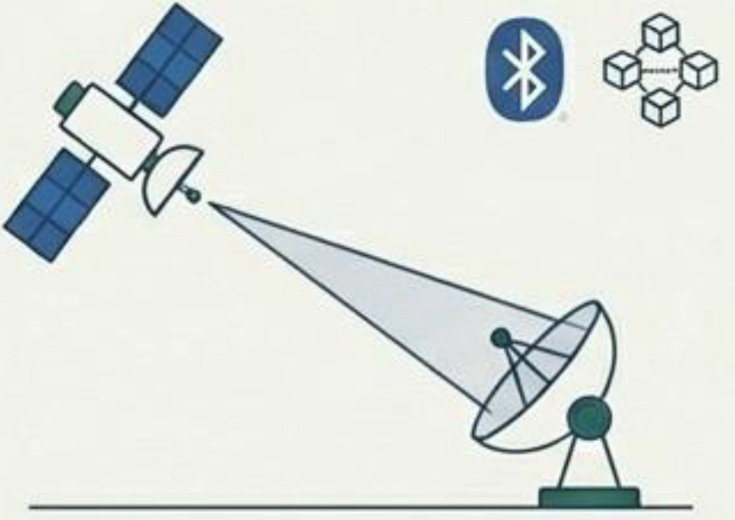

Digital Twins and Data Retention:

Global remote control via AI with predictive maintenance

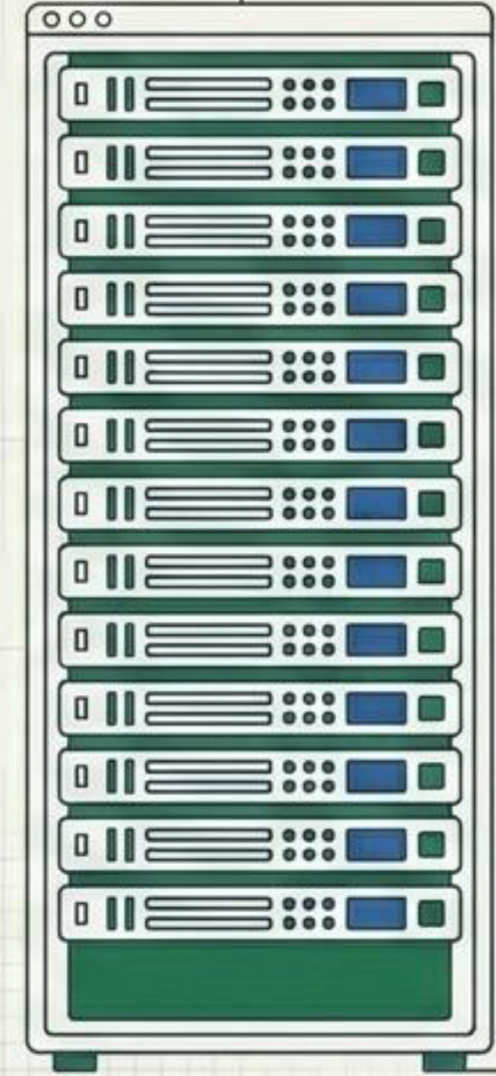

Real Time: Up to 90 days.
Minimum Delay: 91 to 360 days.
Cloud Archive: >360 days.

© 2021 SGP. All rights reserved.

Operational Geographic Independence



Zero Coordinate Restrictions
Full operation at any latitude or longitude.



Altitude Independence
Isolated pressurization ensures operation from sea level to high altitudes.



Minimum Soil Requirements
Requires only a flat and dry area on a leveled vibrastop system

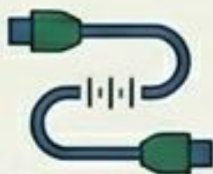

Connection Range
Allows Plug-and-play connection up to 5 km away from the grid (underground cabling)

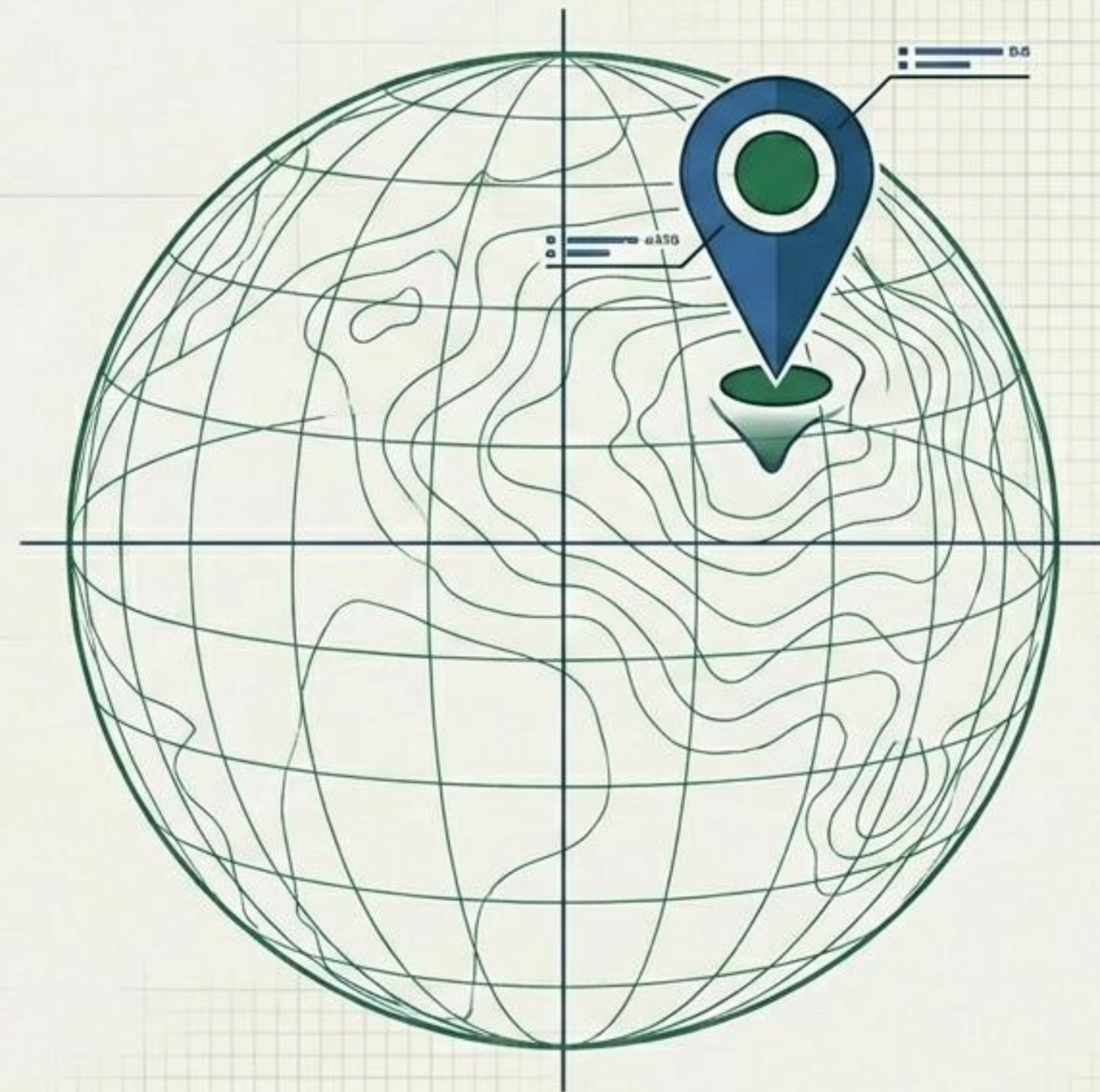

Strategic Positioning: The SGP Does Not Compete with the Macrogrid

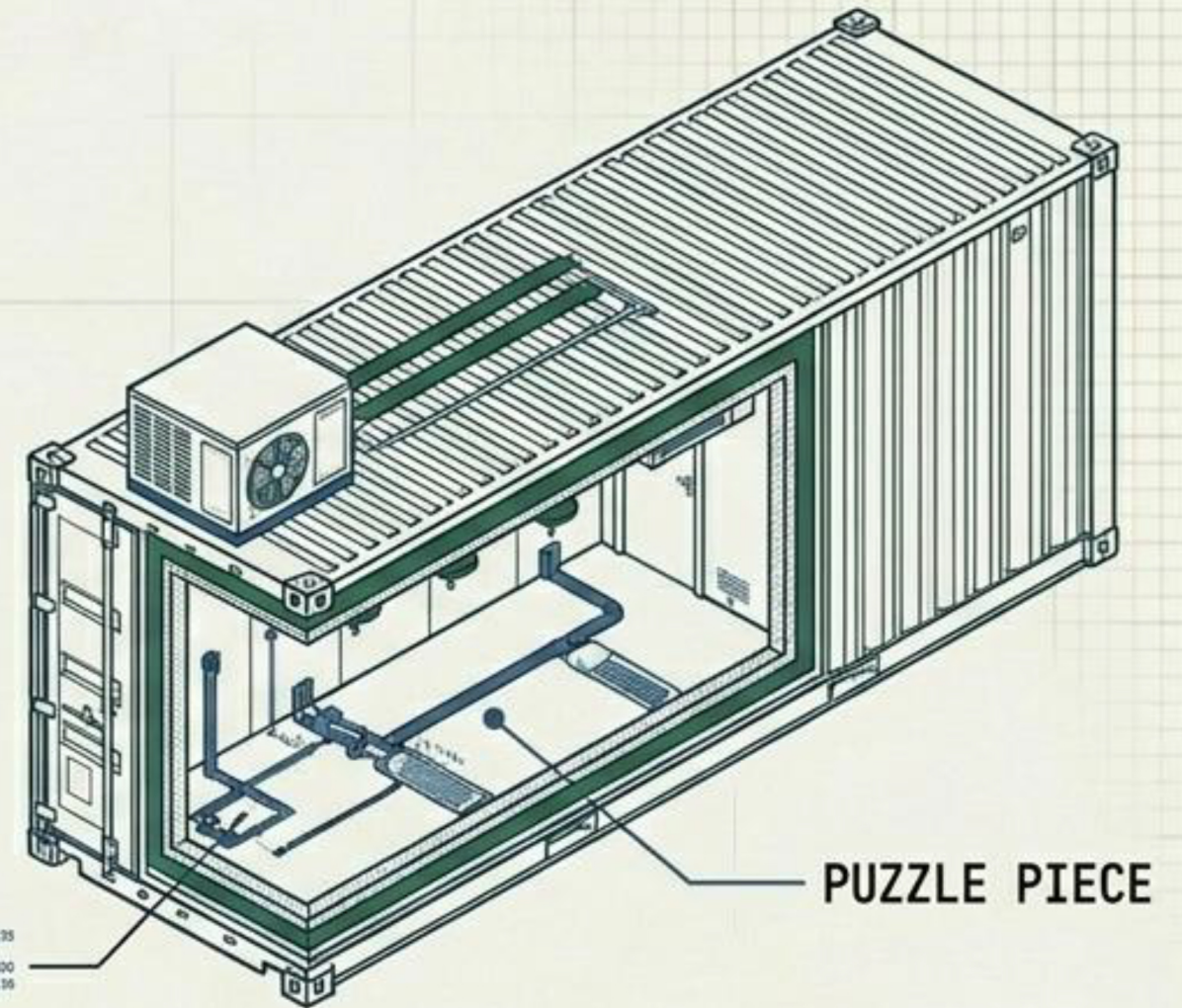
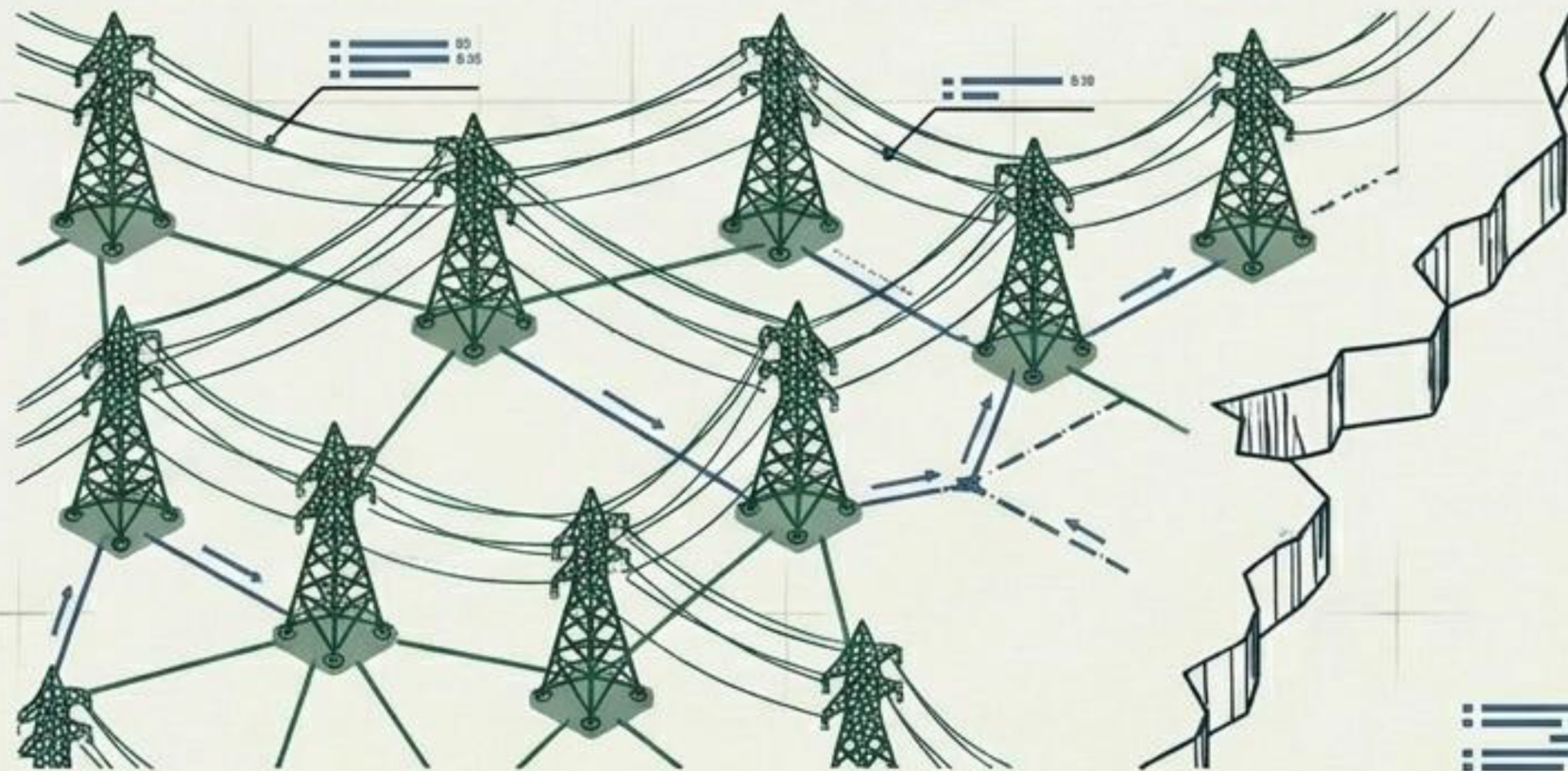



The Missing Piece

The SGP operates in an off-grid Microgrid regime, filling the Brazilian gaps where traditional infrastructure does not reach or does not guarantee 24/7 reliability.

Bidirectional Capacity

Plug-and-play connection that allows supply and return in real time with the main grid or EV networks, absolutely eliminating waste.

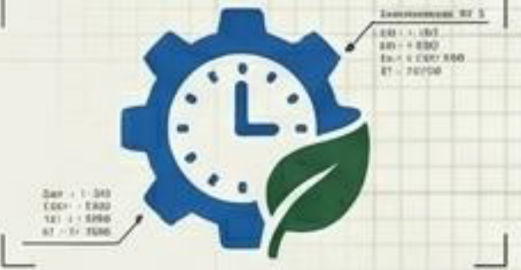
Total Institutional Regulatory Alignment

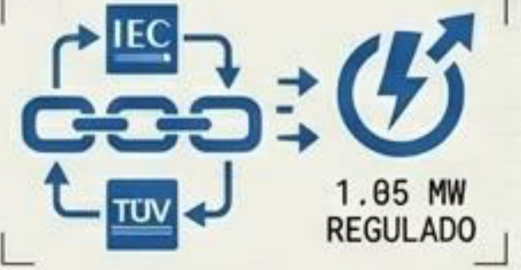
<p>CNPE / MME / EPE</p>	<p>Boosts the MMGD (Micro/Minigeneration) with 100% green energy for long-term sustainable planning (17 years)</p>	
<p>CMSE / ONS</p>	<p>Provides 24/7 energy independent of hydrological regimes, offering continuous support for grid balancing via telemetry</p>	
<p>ANEEL / CCEE</p>	<p>Complies with IEC and TÜV standards, delivering scalable MMGD (1.05 MW regulated) with blockchain for consumers in the free market.</p>	

In full compliance with Brazilian supply security and energy transition

Cax : - 8,788
Eax : 225 NOV

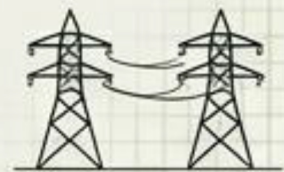

The Absolute Advantage of Smart Grid Power

ESG & Environment:
100% Green and Zero
emissions. Over 5,000
tons of CO2 avoided
annually per MW
generated

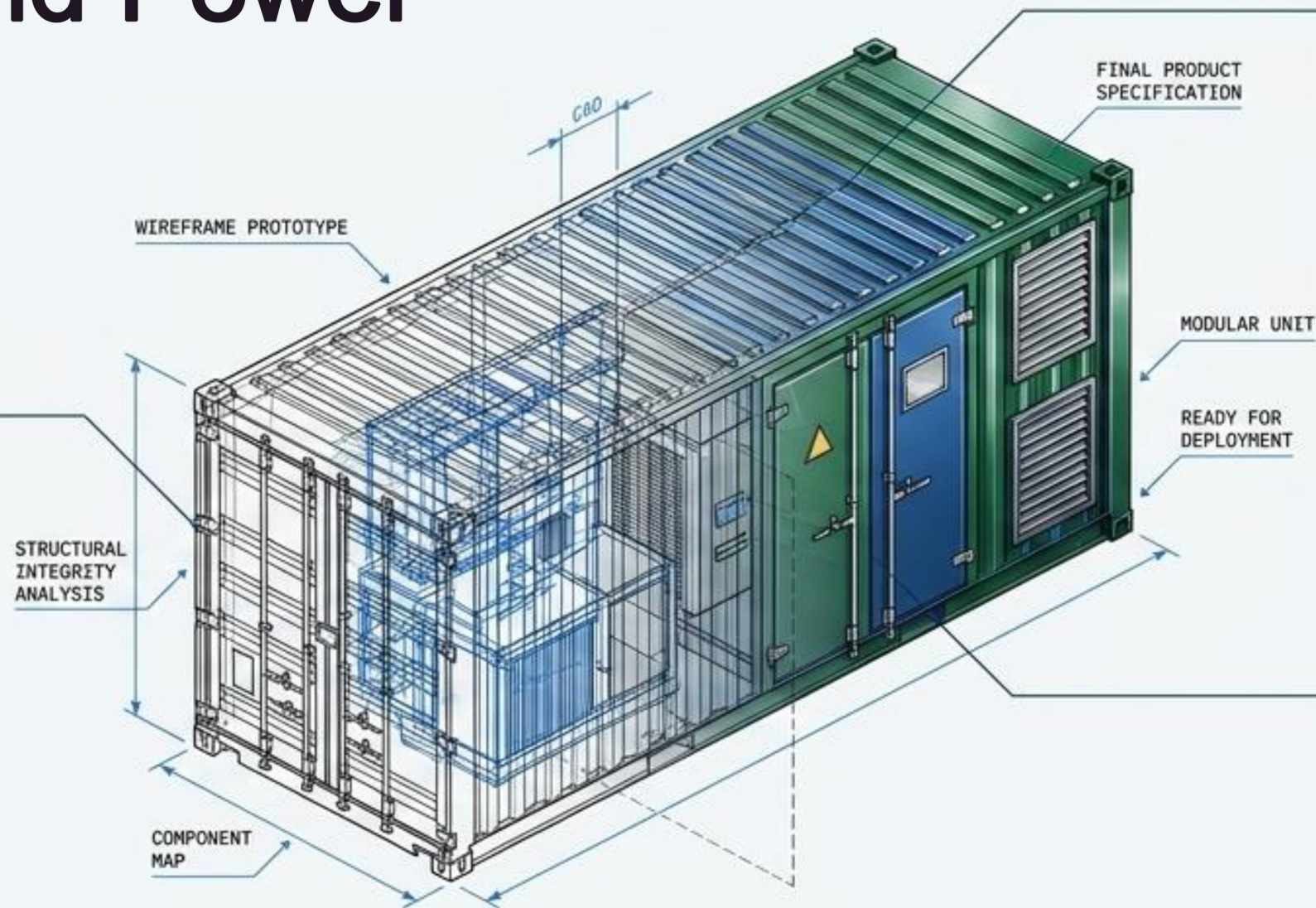

Power Summary: 1.88
MW/h of pure continuous
energy, 60h of storage,
and 100,000 hours of
operation.



Agile Implementation:
Complete deployment
within 270 days under a
Leasing model (service
provision)



A definitive and autonomous transition for
high-demand free consumers in Brazil.

